

THIS DRAWING IS UNPUBLISHED. RELEASED FOR PUBLICATION
 © COPYRIGHT BY TYCO ELECTRONICS CORPORATION. ALL RIGHTS RESERVED.

LOC	DIST	REVISIONS			
P	LTR	DESCRIPTION	DATE	DWN	APVD
AF	50	E1	ECR-06-003925 (REDRAWN IN AUTOCAD)	30JAN06	HMR/GDP

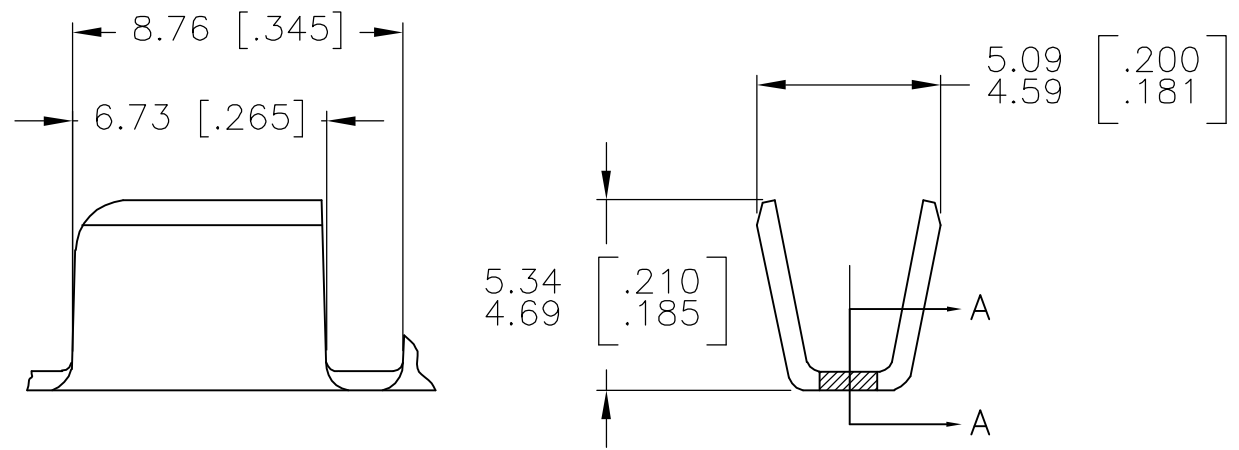

1. PRODUCT PROVIDED IN STRIP FORM ON REELS; BREAKS MAY BE PRESENT.
2. DIMENSIONS IN BRACKETS ARE IN INCHES.
3. CRIMP WIDTH: .140 F (AMPLIVAR TYPE)
 CRIMP HEIGHT (±.002)=(TOTAL CMA+14,600)/243,900
 GENERAL APPLICATION GUIDELINES MUST BE FOLLOWED AS SPECIFIED IN CATALOG #82221
 FOR APPLICATOR INFORMATION CALL: 1-800-722-1111
 FOR PRODUCT INFORMATION CALL: 1-800-522-6752

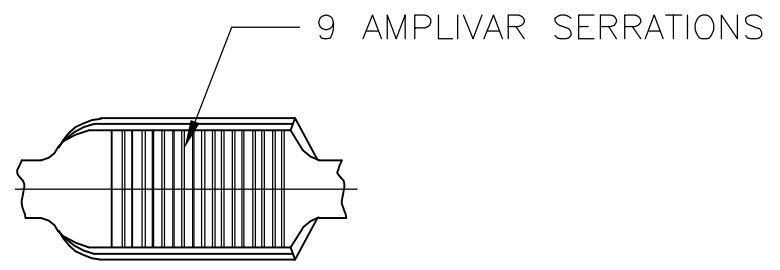
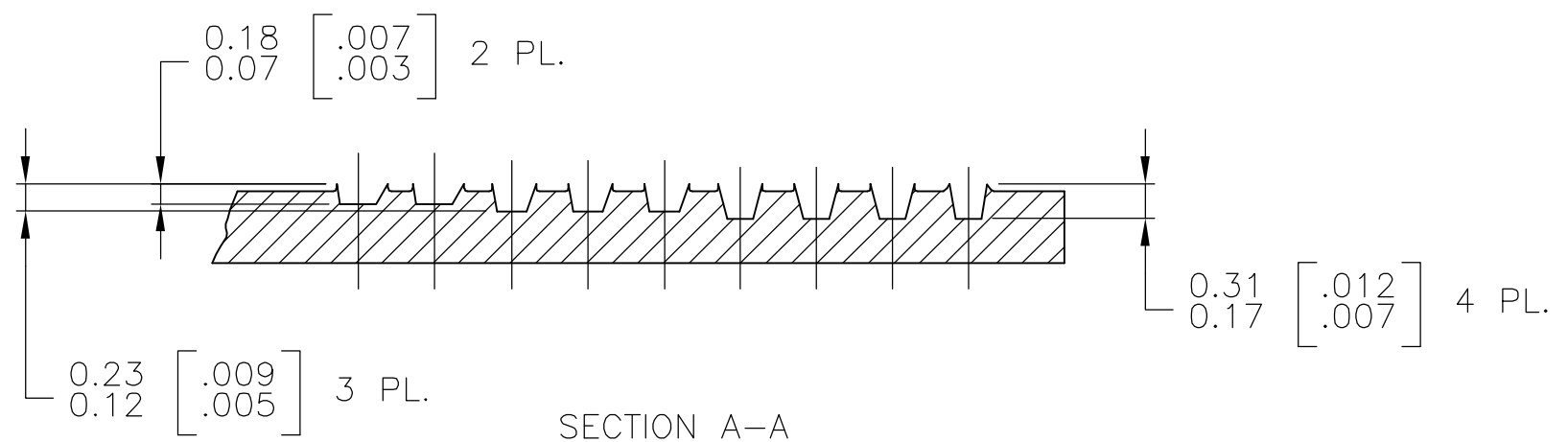

SECTION A-A
 SCALE : 10:1

62308-2
 PART NO

METRIC

THIS DRAWING IS A CONTROLLED DOCUMENT.		DWN RAGHAVENDRA 30JAN06	Tyco Electronics Corporation Harrisburg, Pa 17105-3608	
DIMENSIONS: mm [INCHES]	TOLERANCES UNLESS OTHERWISE SPECIFIED:	CHK G.D.PORTA	NAME	
	0 PLC ± -	APVD G.D.PORTA	PRODUCT SPEC	
	1 PLC ± -	PRODUCT SPEC	APPLICATION SPEC	
	2 PLC ± 0.38[.015]	114-2003	SIZE A3	CAGE CODE 00779
	3 PLC ± -	WEIGHT -	DRAWING NO C-62308	RESTRICTED TO -
	4 PLC ± -	CUSTOMER DRAWING	SCALE 5:1	SHEET 1 OF 1
	ANGLES ± 1'0"		REV E1	
MATERIAL 0.51[.020] BRASS	FINISH TIN PL.			